

HARD-SIDED VOLUMETRIC FEEDER

MATERIAL HANDLING
EXCELLENCE

The Tecweigh® hard-sided volumetric feeder provides a heavy-duty, stainless steel product contact surface and Tecweigh's patented cartridge drive bearing assembly. This feeder's unique design minimizes product build up areas and its "quick disconnect" feature provides tool-less removal of most components, including the auger and feedtube. Tecweigh's design features speed up maintenance and clean up, and make the feeder ideal for sanitary applications.

Tecweigh's cartridge drive bearing assembly saves you time and labor. The drive bearings and seals can be replaced in just minutes, the fastest replacement time in the industry. The drive bearing's cartridge rides on o-rings which absorb the irregular forces generated by a helical auger's rotation. This arrangement increases the bearing's life expectancy.



Tecweigh prides itself on satisfying their customer's needs. Customer requests for specific types of drives, motors, bearings and materials are routine here at Tecweigh. Please contact your local Tecweigh Representative for any special requirements or visit our web site at www.tecweigh.com.

HSE-20

HSF-20

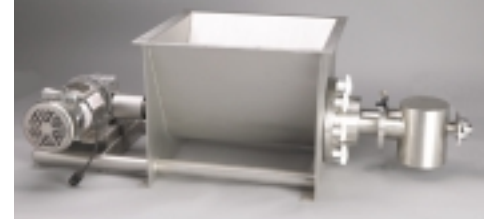

Features

- Heavy-duty construction
- Hopper opening dimensions are 21" x 21"
- Holds 2.0 cubic feet of material
- 303 or 304 stainless steel, 7 gauge product contact surface
- Continuous welded seams
- Glass bead blasted finish

Controls

- NEMA 4 control enclosure (separately mounted)
- SCR DC drive, 40:1 turndown ratio
- Digital speed control potentiometer
- Illuminated push-pull start/stop switch
- Remote start/stop interlock
- 120 VAC input power

Fast Assembly and Disconnect

- Quick disconnect design of auger and feed tube
- Patented cartridge drive bearing assembly

Auger and Feedtube

- 303 or 304 stainless steel
- 2" – 6" diameter augers

Motor and Reducer

- Universal reducer mounting base
- 1/2 HP, 0-90 VDC motor
- Right angle worm gear reducer
- In-line coupling drive

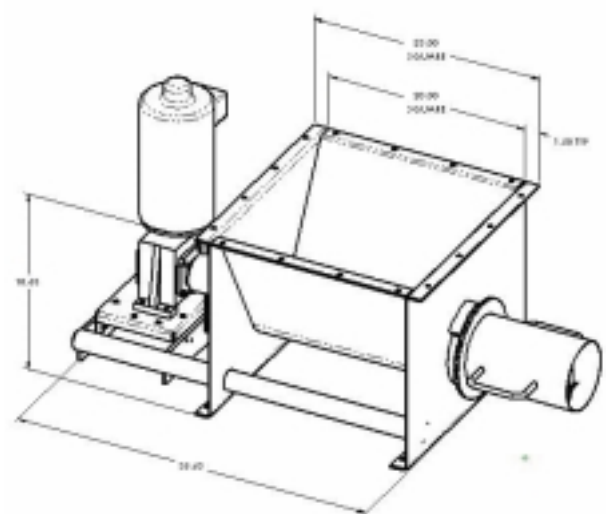

1811 Buerkle Road · Saint Paul, MN 55110
1-800-536-4880 · 651-777-4780 · FAX 651-777-5582

E-mail: sales@tecweigh.com

Web: www.tecweigh.com

In Australia contact:
Tecweigh Proprietary Ltd.
Phone +613 95480922
Web: www.tecweigh.com.au