



WY10 CONVEYOR BELT SCALE

WEIGH THE ADVANTAGES

Nobody makes a conveyor belt scale that's more accurate, more dependable or easier to use than Tecweigh. Nobody gives you better performance or greater value. Tecweigh's 24 hour service hotline coupled with our unique repair program and local service representation show our commitment to providing the best customer service in the industry. Topping it all off, we back it up with our exclusive five year warranty, the longest warranty in the business.

Tecweigh's thoughtful, proven design eliminates common problem areas. Weather-tight, one piece, fully welded construction keeps your line rolling even in the most extreme conditions: dust, dirt, rocks and harsh weather.

Our internal LVDT load sensors simply cannot be overloaded, making blown load cells a thing of the past. Self storing calibration weights, standard equipment for Tecweigh, make the calibration process easy and safe, eliminating clumsy hang-on weights or cal chains.

Tecweigh's weight processors make installation and set up the easiest in the industry. Combine your WY10 scale with any one of our complete family of dedicated weight processors for years and years of trouble free operation. We guarantee it!

The WY10 single idler scale delivers accuracy of $\pm 1/2\%$ in standard belt widths from 18" to 72". If increased accuracy is what you require, our WY20 dual idler scale will provide accuracy of $\pm 1/4\%$.



User friendly WP20 Weight Processor

Higher flow rates? We've got you covered! Tecweigh's custom built WY10 Heavy Duty and WY10 Super Heavy Duty scales can reliably handle flow rates in excess of 10,000 Tons Per Hour in belt widths up to 96".

That's why people who need accuracy and dependability are choosing Tecweigh as their way!

THE BEST WARRANTY IN THE BUSINESS

WY10



Features

- Precision Torque Tube and LVDT load sensors provide precise measurement, eliminate fragile load cells
- LVDT load sensors can't be damaged by overloading
- Impact and weather resistant, stands up to years of rugged use
- Single, dual and four idler models
- Fast, easy installation

Self Storing Calibration Weights

- No bulky chains or awkward hang-ons
- Calibration is quick, easy and safe

Electronic Weight Processor

- Embedded microprocessor technology
- Auto zero/auto span makes calibration quick and easy
- Bright, easy to read, 1/2" LED display
- Full time self diagnostics
- Optional multi-scale processor, feed rate controller and load controller
- All processors provide 4-20 mA analog rate, totalizing pulse relay, remote interlock/reset, RS232/RS485 ports and more

Other Options

- *Wireless Communication*
- *Industrial Network Protocols* (Modbus, Profibus, Ethernet, Devicenet, Allen Bradley R I/O, etc.)
- Chart recorders, data loggers
- Ticket, tape printers
- Scoreboard displays
- Remote rate/total displays

The Longest Warranty in the Industry

Every Tecweigh® Conveyor Belt Scale is covered by our exclusive five year warranty!



STANDARD SPEED SENSOR



OPTIONAL HEAVY DUTY SPEED SENSOR

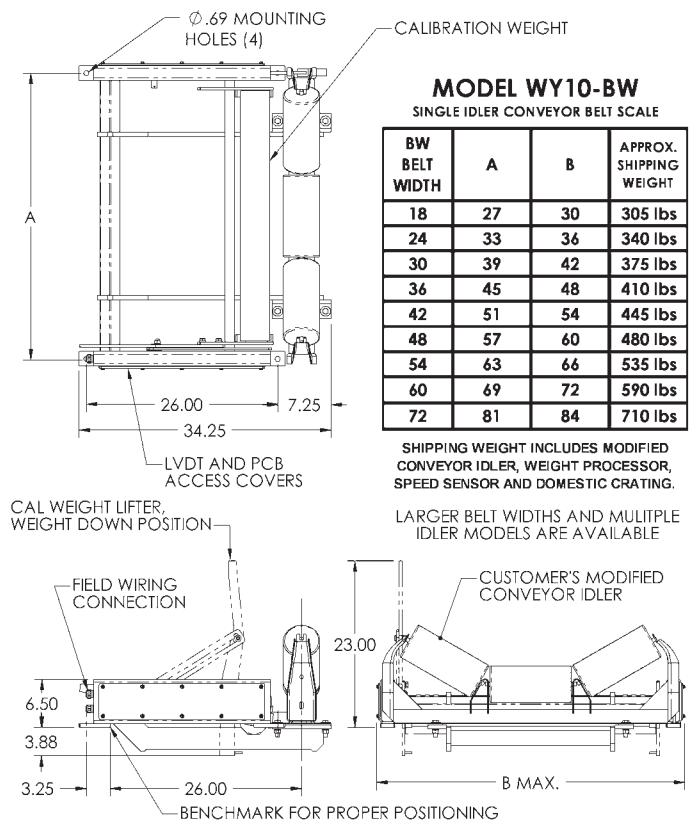

1811 Buerkle Road · Saint Paul, MN 55110
1-800-536-4880 · 651-777-4780 · FAX 651-777-5582

E-mail: sales@tecweigh.com

Web: www.tecweigh.com

In Australia contact:
Tecweigh Proprietary Ltd.
Phone +613 95480922
Web: www.tecweigh.com.au